



**Australian
Building
Codes Board**

Livable Housing Design
Voluntary Standard

BEYOND MINIMUM STANDARD



2022

The Australian Building Codes Board

The Australian Building Codes Board (ABCB) is a standards writing body responsible for the National Construction Code (NCC), WaterMark and CodeMark Certification Schemes.

The ABCB is a joint initiative of all levels of government in Australia, together with the building and plumbing industry. Its mission is to oversee issues relating to health, safety, amenity, accessibility and sustainability in building.

For more information visit the [ABCB website](#).

Copyright

© Commonwealth of Australia and the States and Territories of Australia 2023, published by the Australian Building Codes Board.

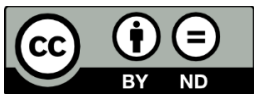

This work is licensed under the Creative Commons Attribution-NonCommercial 4.0 International license with the exception of any third party material, any trademarks, and any images or photographs. You may not make derivatives of this publication, but may only use a verbatim copy. More information on this licence is set out at the [Creative Commons website](#). Enquiries about this publication can be sent to:

Australian Building Codes Board
GPO Box 2013, Canberra ACT 2601
Phone: 1300 134 631
Email: ncc@abcb.gov.au
Web: abcb.gov.au

Attribution

Use of all or part of this publication must include the following attribution:

© Commonwealth of Australia and the States and Territories of Australia 2023, published by the Australian Building Codes Board.

Disclaimer

By accessing or using this publication, you agree to the following:

While care has been taken in the preparation of this publication, it may not be complete or up-to-date. You can ensure that you are using a complete and up-to-date version by checking the [ABCB website](#).

The ABCB, the Commonwealth of Australia and States and Territories of Australia do not accept any liability, including liability for negligence, for any loss (howsoever caused), damage, injury, expense or cost incurred by any person as a result of accessing, using or relying upon this publication, to the maximum extent permitted by law. No representation or warranty is made or given as to the currency, accuracy, reliability, merchantability, fitness for any purpose or completeness of this publication or any information which may appear on any linked websites, or in other linked information sources, and all such representations and warranties are excluded to the extent permitted by law.

This publication is not legal or professional advice. Persons rely upon this publication entirely at their own risk and must take responsibility for assessing the relevance and accuracy of the information in relation to their particular circumstances.

Version history

Original

Publish date: April 2023
Print version: 1.0



Contents

Introduction	1
Background	1
Purpose.....	1
Application.....	1
Referenced documents	2
1 Dwelling access	3
1.1 Step-free access path.....	3
1.2 Parking space incorporated into step-free access path.....	5
2 Dwelling entrance	7
2.1 Clear opening width	7
2.2 Threshold	8
2.3 Landing area	9
2.4 Weatherproofing for external step-free entrance	10
3 Internal doors and corridors	12
3.1 Clear opening width.....	12
3.2 Threshold	13
3.3 Corridor width.....	13
4 Sanitary compartment	14
4.1 Location	14
4.2 Circulation space.....	14
5 Shower	17
5.1 Application	17
5.2 Hobless and step-free entry.....	17
5.3 Dimensions and circulation space.....	18
6 Reinforcement of bathroom and toilet walls	20
6.1 Location	20
6.2 Construction	21
7 Internal stairways	29



7.1 Location	29
7.2 Construction.....	29
8 Kitchen.....	31
8.1 Circulation space.....	31
8.2 Floor finishes.....	31
9 Laundry.....	32
9.1 Circulation space.....	32
9.2 Floor finishes.....	32
10 Bedroom space.....	33
10.1 Location and circulation space.....	33
10.2 Suitability	33
11 Light switches and general power outlets.....	34
11.1 Height and location.....	34
12 Door hardware	35
12.1 Height above finished floor level.....	35

Introduction

Background

This ABCB Voluntary Standard ('Voluntary Standard') is a set of non-mandatory technical provisions that if complied with will enable dwellings to better meet the needs of the community, including older people and people with mobility limitations.

This Voluntary Standard has been adapted from the 'Gold' level provisions of the Livable Housing Design Guidelines (LHDG), fourth edition, 2017, which were first published by Livable Housing Australia. It is important to note that this Voluntary Standard is not an exact replication of the LHDG.

Purpose

The purpose of this Voluntary Standard is to provide a greater level of livable design than the minimum set out in the NCC and the ABCB Standard for Livable Housing Design. This is achieved through additional and enhanced provisions as compared to the ABCB Standard for Livable Housing Design.

This Voluntary Standard is not intended for use in designing specialist accommodation, nor is it intended to achieve equivalence with Australian Standard (AS) 1428.1. Therefore, it may not accommodate the abilities of all home occupants. Nonetheless, the enhanced and additional features described herein would benefit most home occupants.

Application

This Voluntary Standard is a guidance publication. It is not mandatory to use this Voluntary Standard for compliance with any part of the NCC. However, if a user chooses to comply with this Voluntary Standard instead of the ABCB Standard for Livable Housing Design, they can still achieve compliance with the NCC as a Deemed-to-Satisfy (DTS) Solution. This is because the recommendations in this Voluntary Standard exceed the minimum DTS Provisions of the ABCB Standard for Livable Housing Design.

This Voluntary Standard is intended to apply to Class 1a buildings (houses and the like) and Class 2 *sole-occupancy units* (apartments), as defined in the NCC.

Terms with specific meaning

In this Voluntary Standard, terms shown in *italicised text* have the meaning that they have in the NCC.

Referenced documents

The documents listed in Table 1 are referenced in this Voluntary Standard.

Table 1: Referenced documents

Number	Date	Title	References
AS/NZS 1170 Part 1	2002	Structural design actions – permanent and imposed actions (including Amendments 1 and 2)	1.1
AS 1684 Part 2	2021	Residential timber-framed construction — Non-cyclonic areas	1.1
AS 1684 Part 3	2021	Residential timber-framed construction — Cyclonic areas	1.1
AS 1684 Part 4	2010	Residential timber-framed construction—Simplified— Non-cyclonic areas (incorporating amendment 1)	1.1
AS 3959	2018	Construction of buildings in bush-fire-prone areas (incorporating amendments 1 and 2)	2.4
NASH Standard Parts 1 and 2	Part 1: 2005 (incorporating Amendments A, B and C) Part 2: 2014 (incorporating Amendment A)	Residential and low-rise steel framing	1.1

1 Dwelling access

1.1 Step-free access path

- (1) A continuous path to a dwelling entrance door must be provided from—
 - (a) the pedestrian entry at the allotment boundary from the ground level of the adjoining land; or
 - (b) an appurtenant Class 10a garage or carport; or
 - (c) a car parking space within the allotment that is provided for the exclusive use of the occupants of the dwelling.
- (2) Access for the purposes of (1) must be—
 - (a) via a pathway that—
 - (i) has no steps; and
 - (ii) except for a step ramp provided under (5), has a maximum gradient of 1:14 in the direction of travel; and
 - (iii) if crossfall is provided, has a crossfall not more than 1:40; and
 - (iv) has a minimum width of 1100 mm; and
 - (v) if it incorporates a section suspended above finished ground level, is able to take loading forces in accordance with AS/NZS 1170.1; and
 - (vi) connects to a dwelling entrance door that complies with Section 2; or
 - (b) provided directly from an attached Class 10a garage or carport via a door that complies with the requirements of Section 2, other than Clause 2.3.
- (3) For the purposes of (2), the following applies:
 - (a) Any gates along the access path must have a minimum clear opening width of 850 mm, measured as if the gate were an entrance door.
 - (b) A deck or boardwalk-style path constructed in accordance with AS 1684 or NASH Standard – Residential and Low-rise Steel Framing would satisfy the requirements of (2)(a)(v).
- (4) Where one or more ramps are used, the following applies:
 - (a) The interval between landings must be not more than—
 - (i) 9 m for a 1:14 gradient; or
 - (ii) 15 m for a 1:20 gradient; or

- (iii) a length determined by linear interpolation for ramps with a gradient between 1:14 and 1:20.
 - (b) The minimum width of the ramp must be maintained at 1100 mm between any handrails and/or kerbs (if provided) at each side of the ramp.
 - (c) At each end of the ramp there must be a landing that is—
 - (i) not less than 1200 mm long; and
 - (ii) at least as wide as the ramp to which it connects; and
 - (iii) level, or has a gradient not more than 1:40 if a gradient is necessary for drainage.
 - (d) A landing area required by Clause 2.3 may also be counted as a landing for the purposes of (c).
- (5) The access path may incorporate one step ramp having a—
- (a) height of not more than 190 mm; and
 - (b) gradient of not more than 1:10; and
 - (c) width of at least 1100 mm or equivalent of the access path, whichever is the greater; and
 - (d) maximum length of 1900 mm.

Applications

Clause 1.1 only applies to a Class 1a building.

Information: Access via a garage, carport or parking space

Where step-free access is provided from a garage, carport or parking space, this can be through a connecting door between the garage, carport or parking space and the dwelling. The connecting door need not be the main entrance (sometimes referred to as the 'front door') but would need to comply with Section 2. Any carparking spaces forming part of the required path of travel must be free of obstructions, including structural elements such as columns or engaged brick piers that would otherwise reduce the space for free movement.

Information: Class 2 buildings

For a Class 2 building, requirements for a step-free access path are provided in Section D of NCC Volume One and the 'Disability (Access to Premises—Buildings) Standard 2010'. Therefore, Clause 1.1 only applies to a Class 1a building.

Comparison to the ABCB Standard for Livable Housing Design

In the ABCB Standard for Livable Housing Design:

- The required minimum width of the step-free access path (including any ramps) is 1000 mm, rather than 1100 mm.
- The minimum clear opening width required by Clause (3)(a) is 820 mm, rather than 850 mm.

1.2 Parking space incorporated into step-free access path

- (1) Where one or more car parking spaces are connected to or form part of a required access path, at least one of the car parking spaces must have—
 - (a) a minimum unobstructed car parking space of 3200 mm wide x 5400 mm long; and
 - (b) a gradient not more than 1:33 for bitumen, or 1:40 for any other surface material; and
 - (c) cover from the weather with a minimum vertical clearance of 2500 mm over the car parking space.
- (2) For the purposes of (1), a required access path means an access path provided for the purposes of compliance with Clause 1.1.

Applications

- (1) Clause 1.2 only applies to a car parking space provided for the exclusive use of the occupants of the dwelling.
- (2) Clause 1.2 does not apply—
 - (a) if there are no car parking spaces provided for the exclusive use of the occupants of the dwelling; or
 - (b) to a Class 2 building.

Comparison to the ABCB Standard for Livable Housing Design

In the ABCB Standard for Livable Housing Design, subclause (1)(c) is omitted.

2 Dwelling entrance

2.1 Clear opening width

- (1) At least one entrance door to the dwelling must have a minimum clear opening width of 850 mm.
- (2) The minimum clear opening width required by (1) must be measured in accordance with Figure 2.1.

Figure 2.1.a Measurement of clear opening width

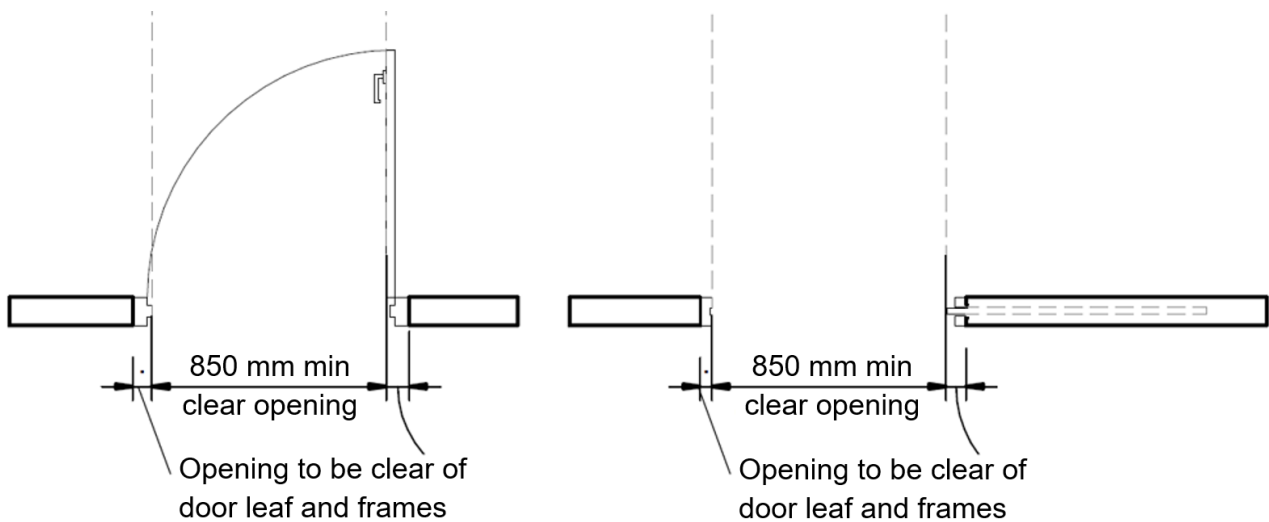

Notes to Figure 2.1:

- (1) Double doors, bi-fold doors, stacking doors, multiple sliding door panels and other types of hinged door sets may use a smaller leaf provided the overall clear opening width with the doors fully open is not less than 850 mm.
- (2) Clear opening width for sliding doors must be measured with the door panel(s) installed and in the fully open position.
- (3) The door handle may encroach the required minimum clear opening width.

Information: Door leaf dimensions

An 850 mm clear opening width, for a single swinging door, can generally be achieved using a 920 mm door leaf.

Information: Meaning of 'entrance door'

An entrance door for the purposes of 2.1 may be a door other than the front door, provided that the door connects to the step-free access path in accordance with Clause 1.1(2). For example, compliance with 2.1 could be achieved via a side door that is connected to the garage via a step-free path.

Comparison to the ABCB Standard for Livable Housing Design

In the ABCB Standard for Livable Housing Design, the minimum clear opening width required by Clause (1) is 820 mm, rather than 850 mm.

2.2 Threshold

The threshold of an entrance door subject to Clause 2.1 must—

- (a) be level; or
- (b) have a sill height not more than 5 mm if the lip is rounded or bevelled; or
- (c) have a ramped threshold that—
 - (i) does not extend beyond the depth of the door jamb; and
 - (ii) has a gradient not steeper than 1:8; and
 - (iii) is at least as wide as the minimum clear opening width of the entrance door; and
 - (iv) does not intrude into the minimum dimensions of a landing area that is required by Clause 2.3; or
- (d) where the requirements of (a), (b), or (c) cannot meet the weatherproofing requirements of the NCC—
 - (i) for external entrance doors containing a raised door sill, have no lip or upstand greater than 15mm within the sill profile; and
 - (ii) adjoin finished surfaces with a difference in finished surface level no greater than 5mm.

Information: Finished surfaces abutting a door sill

The finished surfaces abutting a door sill will involve the external surface on one side and the internal floor finish on the other side. Finished surfaces may include a carpet or tiled finish internally, or decking, paving or the like externally. Door mats should not be counted as forming a finished surface either side of the door sill.

Information: Termite management

For termite management, where *required* by the NCC, the NCC referenced document AS 3660.1 includes solutions for termite management in cases where there is no step-up into a dwelling: see clauses 2.2, 2.3, 4.4 and 6.5 of AS 3660.1.

AS 3660.1 is referenced in the NCC, therefore an appropriate solution for termite management that complies with AS 3660.1 can be used as part of a *Deemed-to-Satisfy Solution* under the NCC.

Information: Damp-proof course

For masonry construction, a *damp-proof course* is to be located above the external finished surface (e.g. clause 5.7.4 of the ABCB Housing Provisions). Therefore, the construction of a ramp, threshold or the like is to maintain compliance with this requirement.

Comparison to the ABCB Standard for Livable Housing Design

This clause is identical to Clause 2.2 of the ABCB Standard for Livable Housing Design.

2.3 Landing area

An entrance door that is subject to Clause 2.1 must have a space of at least 1350 mm x 1350 mm on the external (arrival) side of the door that is—

- (a) unobstructed (other than by a gate or screen door); and
- (b) level, or has a gradient not more than 1:40 if a gradient is necessary to allow for drainage.

Applications

- (1) Clause 2.3 only applies to a Class 1a building.
- (2) Clause 2.3 does not apply to a dwelling that is exempt from compliance with Clause 1.1.
- (3) Clause 2.3 does not apply to an entrance door that serves an appurtenant Class 10a garage or carport in accordance with Clause 1.1(b).

Information: Entrance doors to Class 2 sole-occupancy units

Requirements for landing areas outside the entrance door to a Class 2 *sole-occupancy unit* located on an *accessible* floor are set out in Section D of NCC Volume One and the Disability (Access to Premises—Buildings) Standard 2010.

Comparison to the ABCB Standard for Livable Housing Design

In the ABCB Standard for Livable Housing Design, the minimum landing area required by Clause 2.3 is 1200 mm x 1200 mm, rather than 1350 mm x 1350 mm.

2.4 Weatherproofing for external step-free entrance

Weatherproofing for an external step-free entrance must be provided in accordance with one or a combination of the following:

- (a) Where the external surface is concrete or another impermeable surface, a channel drain that meets the requirements of Volume Two H2D2 is to be provided for the width of the entrance.
- (b) Where the external trafficable surface is decking or another raised permeable surface, a drainage surface below the trafficable surface is to be provided that meets the requirements of Volume Two H2D2, and drainage gaps in the trafficable surface, such as those between decking boards, are to be no greater than—
 - (i) 8 mm: or
 - (ii) in a *designated bushfire prone area*, that permitted by AS 3959.
- (c) A roof covering an area no smaller than 1200 mm by 1200 mm, where the area is provided with a fall away from the building no greater than 1:40.

Applications

- (1) The provisions of Clause 2.4 do not apply to an entrance door that is provided through an interconnected garage.
- (2) A channel drain provided in accordance with (a) can also act as an inspection zone for the purposes of termite management provisions provided the inspected zone required by AS 3660.1 can be accessed.
- (3) Consideration should be given to the ability for cleaning drains in (a), particularly in bushfire prone areas.
- (4) For the purposes of (c), any posts, columns, or structural supports for the roof cover must not encroach the clear space required by 1.1(4) for a landing or entrance path provided under Clause 1.1.

Comparison to the ABCB Standard for Livable Housing Design

This clause is identical to Clause 2.4 of the ABCB Standard for Livable Housing Design.

3 Internal doors and corridors

3.1 Clear opening width

Internal doorways must provide a minimum clear opening width of 850 mm, measured in accordance with **Error! Reference source not found.**

Applications

Clause 3.1 only applies to a doorway that connects to, or is in the path of travel to, any—

- (a) *habitable room* or laundry on the ground or entry level; or
- (b) attached Class 10a garage or carport that forms part of an access path required by Clause 1.1; or
- (c) *sanitary compartment* on the ground or entry level complying with Parts 4 and 6; or
- (d) room containing a shower complying with Parts 5 and 6.

Information: Clear opening width

An 850 mm clear opening width for a hinged door can be achieved using a 920 mm door leaf.

Information: Split level designs

The requirements of Clause 3.1 do not prevent the use of split levels within the dwelling, including on the ground or entrance level. However, where a split level is used in the path of travel to one or more of the doors listed in the Application, those doors will still need to comply with Clause 3.1.

Comparison to the ABCB Standard for Livable Housing Design

In the ABCB Standard for Livable Housing Design, the minimum clear opening width required by Clause 3.1 is 820 mm, rather than 850 mm.

3.2 Threshold

The threshold of an internal doorway that is subject to Clause 3.1 must—

- (a) be level; or
- (b) have a height not more than 5 mm if the lip is rounded or bevelled; or
- (c) have a ramped threshold that—
 - (i) does not extend beyond the depth of the door jamb; and
 - (ii) has a gradient not steeper than 1:8; and
 - (iii) is at least as wide as the minimum clear opening width of the doorway it serves.

Comparison to the ABCB Standard for Livable Housing Design

This clause is identical to Clause 3.2 of the ABCB Standard for Livable Housing Design.

3.3 Corridor width

Internal corridors, hallways, passageways or the like, if connected to a door that is subject to Clause 3.1, must have a minimum clear width of 1200 mm, measured between the finished surfaces of opposing walls.

Applications

Clause 3.3 does not apply to a stairway that is in the path of travel to a shower complying with Parts 5 and 6 that is on a level other than the ground or entry level.

Information

Skirting boards, architraves, timber mouldings, skirting tiles, door stops, conduits, general power outlets and the like may be disregarded for the purposes of compliance with Clause 3.3. Door hardware may encroach the required minimum corridor width.

Comparison to the ABCB Standard for Livable Housing Design

In the ABCB Standard for Livable Housing Design, the minimum corridor width required by Clause 3.3 is 1000 mm, rather than 1200 mm.

4 Sanitary compartment

4.1 Location

There must be at least one *sanitary compartment* located on the ground or entry level of a dwelling.

Information

The term *sanitary compartment* refers to a room or space containing a toilet. It applies equally to any type of room or space containing a toilet, such as a bathroom, ensuite, powder room or other separate room. It is used in place of the word 'toilet' for consistency with the wording of the NCC and to avoid confusion with the use of the word 'toilet' to refer to a plumbing fixture rather than the room in which that fixture is located. 'At least one *sanitary compartment*' means that in a dwelling with two or more *sanitary compartments*, only one needs to be located on the ground or entry level and comply with the requirements of this Part.

Comparison to the ABCB Standard for Livable Housing Design

This clause is identical to Clause 4.1 of the ABCB Standard for Livable Housing Design.

4.2 Circulation space

A *sanitary compartment* that is subject to Clause 4.1 must be constructed in accordance with the following:

- (a) For a toilet pan located in a separate *sanitary compartment*, there must be a clear width of not less than 1200 mm between the finished surfaces of opposing walls either side of the toilet pan
- (b) For a room containing a toilet pan, any fixed obstruction, such as a basin or a vanity unit, must be located at least 450 mm from the centreline of the toilet pan normal to the front face of the cistern.
- (c) A clear minimum circulation space of 1200 mm by 1200 mm must be provided from the front edge of the toilet pan.
- (d) Compliance with (c) must be determined in accordance with Figure 4.2.

Applications

4.2(c) requires that a minimum circulation space of 1200 mm long by 1200 mm wide clear space be provided in front of the toilet pan, and this applies for both a separate *sanitary compartment* and for a *sanitary compartment* that is combined with a bathroom. The minimum circulation space must be clear of the door swing and applies regardless of whether the door is inwards or outwards swinging or is a cavity slider.

Figure 4.2 Circulation space for a toilet pan

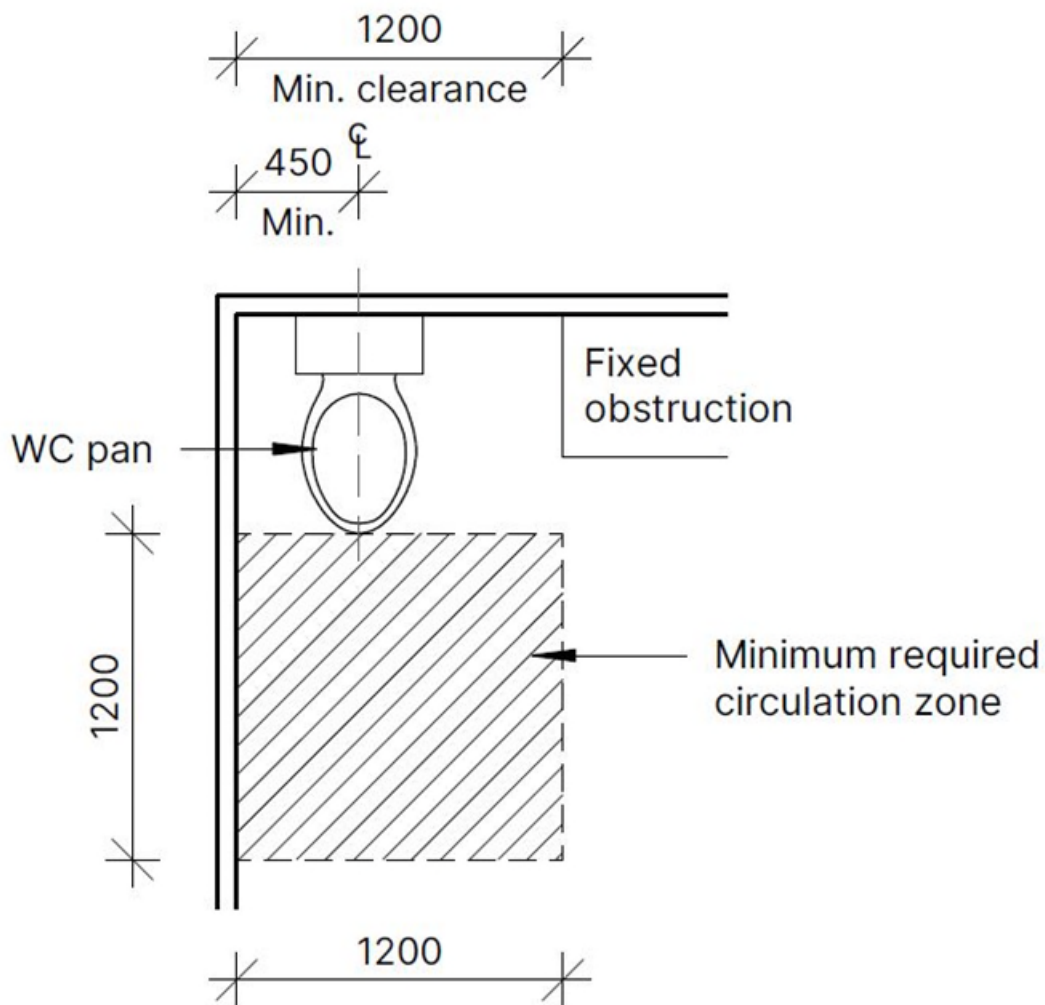

Information

- (1) NCC Volumes One and Two also contain requirements for the location and construction of *sanitary compartments*.
- (2) NCC Volume Three contains requirements for *plumbing* and *drainage* installations in *sanitary compartments*.
- (3) Skirting boards, architraves, toilet roll holders, skirting tiles, door stops and the like may be disregarded when determining compliance with Clause 4.2.

Comparison to the ABCB Standard for Livable Housing Design

In the ABCB Standard for Livable Housing Design:

- The minimum width required between the finished surfaces of opposing walls either side of the toilet pan is 900 mm, rather than 1200 mm.
- The minimum clear opening width of the doors shown in Figure 4.2 is 820 mm, rather than 850 mm.
- The minimum clear circulation space provided at the front of the toilet plan shown in is 900 mm wide x 1200 mm long, rather than 1200 mm wide x 1200 mm long.

5 Shower

5.1 Application

At least one shower must—

- (a) be located on the ground or entry level of the dwelling; and
- (b) comply with the requirements of this Part.

Information

‘At least one shower’ means that in a dwelling with two or more showers, only one of the showers needs to comply with the requirements of this Part.

Comparison to the ABCB Standard for Livable Housing Design

In the ABCB Standard for Livable Housing Design, Clause 5.1(a) is omitted.

5.2 Hobless and step-free entry

- (1) At least one shower must have a hobless and step-free entry.
- (2) A lip not more than 5 mm in height may be provided for water retention purposes.

Applications

For the purposes of Clause 5.2, a lip meeting the requirements of 5.2(2) is not a step.

Information: hobless and step-free entry

Clause 5.2(1) refers to a shower entry being ‘hobless’ and ‘step-free’ because those two terms have different meanings. A shower where the floor within the shower compartment is level with the floor adjacent to its entry would be ‘step-free’ but could still have a hob. Conversely, a shower with a step-down into the shower recess does not have a ‘hob’ (i.e. ‘hobless’), but would not be ‘step-free’. Therefore, to achieve the intent of Clause 5.2(1), it is necessary to specify that the shower is both ‘hobless’ and ‘step-free’.

Information: Waterproofing

AS 3740 and Part 10.2 of the ABCB Housing Provisions include specific requirements for waterproofing a hobless, step-free shower area. Both are referenced in the NCC *Deemed-to-Satisfy Provisions* for general waterproofing of *wet areas* (note that Part 10.2 of the ABCB Housing Provisions only applies to Class 1 and 10 buildings).

Comparison to the ABCB Standard for Livable Housing Design

This clause is identical to Clause 5.2 of the ABCB Standard for Livable Housing Design.

5.3 Dimensions and circulation space

The shower must have dimensions of not less than 900 mm x 900 mm, with a clear space of not less than 1200 mm x 1200 mm adjacent to the shower, as shown in Figure 5..

Figure 5.3 Shower dimensions and circulation space

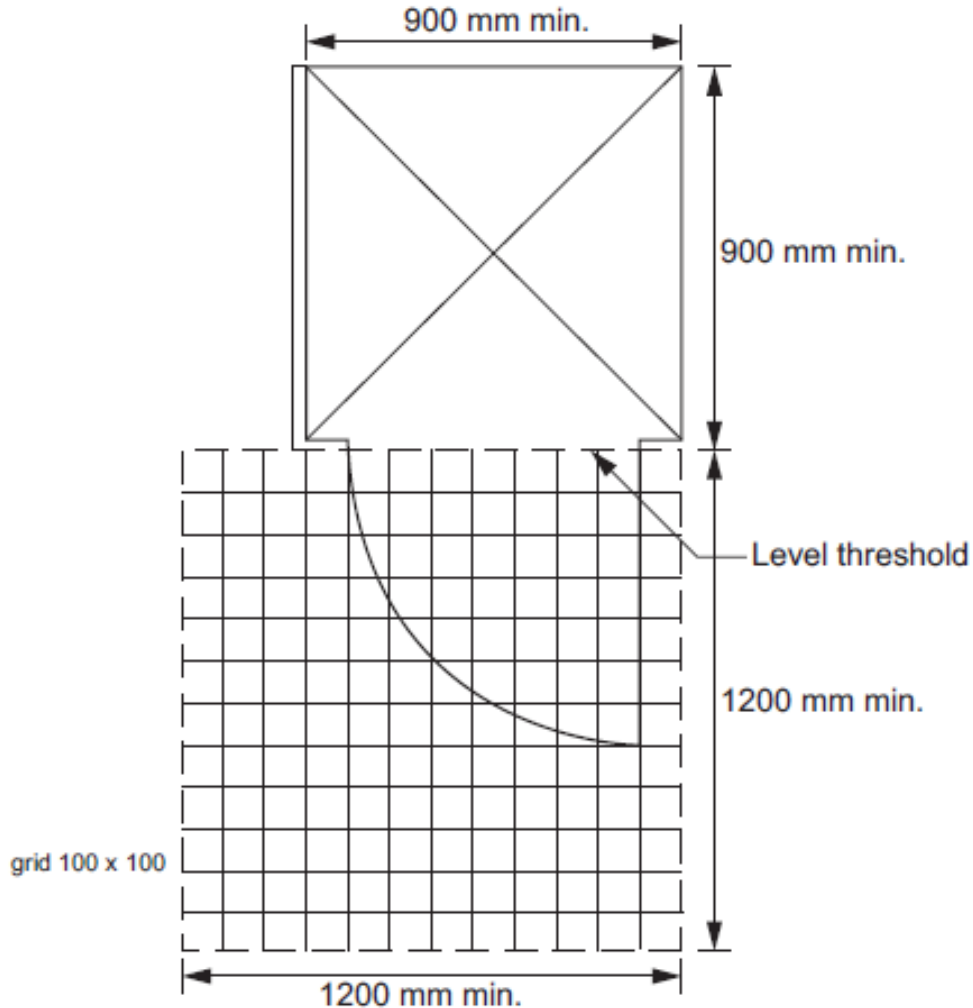

Notes to Figure 5.3:

'Level threshold' means a shower entry complying with Clause 5.2.

A shower door is not a requirement.

Comparison to the ABCB Standard for Livable Housing Design

In the ABCB Standard for Livable Housing Design, Clause 5.3 is omitted.

6 Reinforcement of bathroom and toilet walls

6.1 Location

- (1) Reinforcing in accordance with Clause 6.2 must be provided to any—
 - (a) *sanitary compartment* that is subject to Part 4; and
 - (b) bathroom containing a—
 - (i) shower that is subject to Part 5; or
 - (ii) bath (if provided), other than a freestanding bath where the bath is located in a room that also contains a shower that is subject to Part 5.
- (2) The requirements of (1) need not be complied with if the walls of the room are constructed of concrete, masonry or another material capable of supporting grabrails without additional reinforcement.
- (3) Where the wall supporting the reinforcement includes a cavity slider, it must be designed and constructed in way to support loads imposed by reinforcement, linings and the future provision of handrails and provided for the extent *required* by Figure 6.2a, Figure 6.2b, Figure 6.2c, Figure 6.2d, Figure 6.2e, Figure 6.2f, and Figure 6.2g.

Information: Intent of Part 6

The intent of this Part is to ensure that walls adjacent to toilet pans, showers and baths provide a fixing surface able to support the future installation of grabrails, if needed. This Part does not require the installation of grabrails at the time of construction.

A freestanding bath is excluded from Clause 6.1(1)(b)(ii) because it does not have any adjoining walls to which grabrails could be fixed.

A bath with only one adjoining wall need only have reinforcing provided in the adjoining wall (unless exempted by Clause 6.1(2)).

Care is required when locating a cavity sliding door adjacent to a fixture which requires reinforcement to 6.1(1) as the framing that surrounds the cavity into which the door retracts demands careful consideration of fixings and members that will safely support a grabrail and not impede the operation of the door.

Information: Non-combustibility of walls

Where noggings are required to achieve compliance with this Part, provided they do not extend further than necessary, these noggings may be installed within an *external wall* that is required to be *non-combustible* under C2D10(4)(i)(ii) of NCC Volume One.

Comparison to the ABCB Standard for Livable Housing Design

This clause is identical to Clause 6.1 of the ABCB Standard for Livable Housing Design.

6.2 Construction

- (1) Reinforcing constructed in accordance with the requirements of (3) must be provided in the locations depicted in—
 - (a) Figure 6.2a or Figure 6.2b for walls surrounding a bath; and
 - (b) Figure 6.2c or Figure 6.2d for shower walls; and
 - (c) Figure 6.2e for a wall adjacent to and within 460 mm of the centreline of a toilet pan; and
 - (d) Figure 6.2f or Figure 6.2g for a wall behind a toilet pan where a wall described in (c) is not provided or a window sill or a door encroaches on the area *required* to be provided with reinforcing or where the toilet pan is not provided in a corner of the bathroom.
- (2) Reinforcing need only be provided across the available width of the wall where a wall referred to (1)(a) or (b)—
 - (a) is narrower than the width of the area *required* to be provided with reinforcing; or
 - (b) terminates at a window sill lower than the height of the area required to be provided with reinforcing.
- (3) Reinforcing required by (1) must be constructed using one of the following materials:
 - (a) A minimum of 12 mm thick structural grade plywood, or similar.
 - (b) Timber noggings with a minimum thickness of 25 mm.
 - (c) Light gauge steel framing noggings or metal plate in accordance with the NASH Standard.

Figure 6.2a Location of noggings for walls surrounding a bath

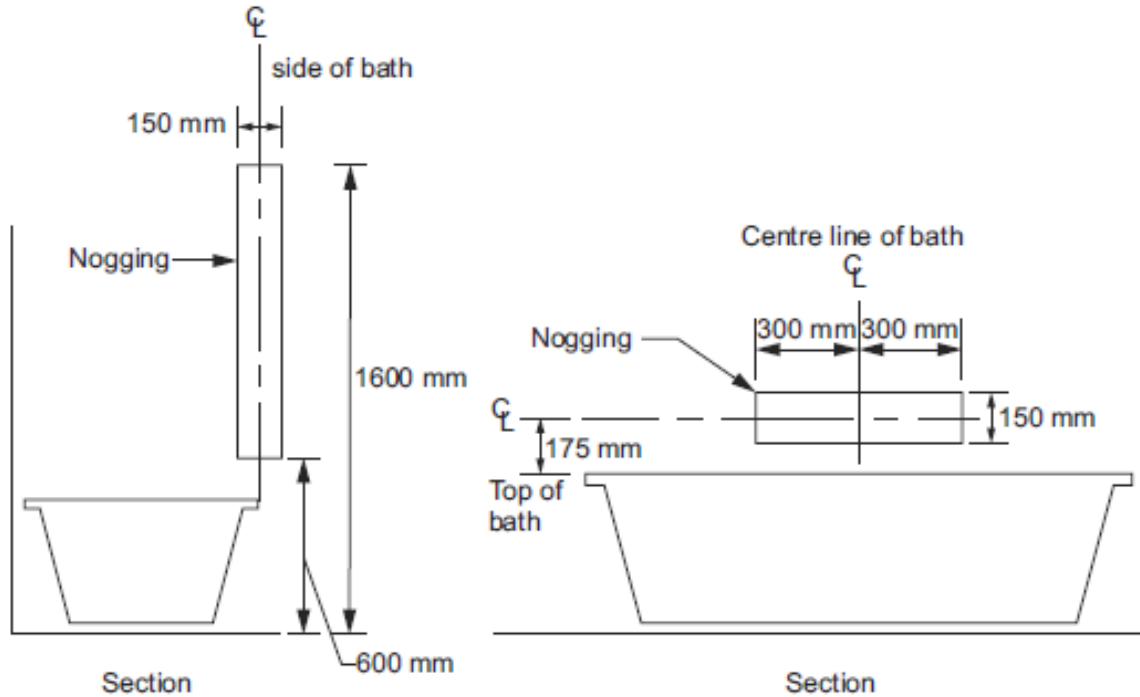

Notes to Figure 6.2a:

- (1) Taps, bath niches, soap holders and the like may be located within the positions designated for wall reinforcing.
- (2) Where the height of the bathtub is not yet known, an assumed height of 500 mm above finished floor level may be used to determine the location of wall reinforcing.

Figure 6.2b Location of sheeting for walls surrounding a bath

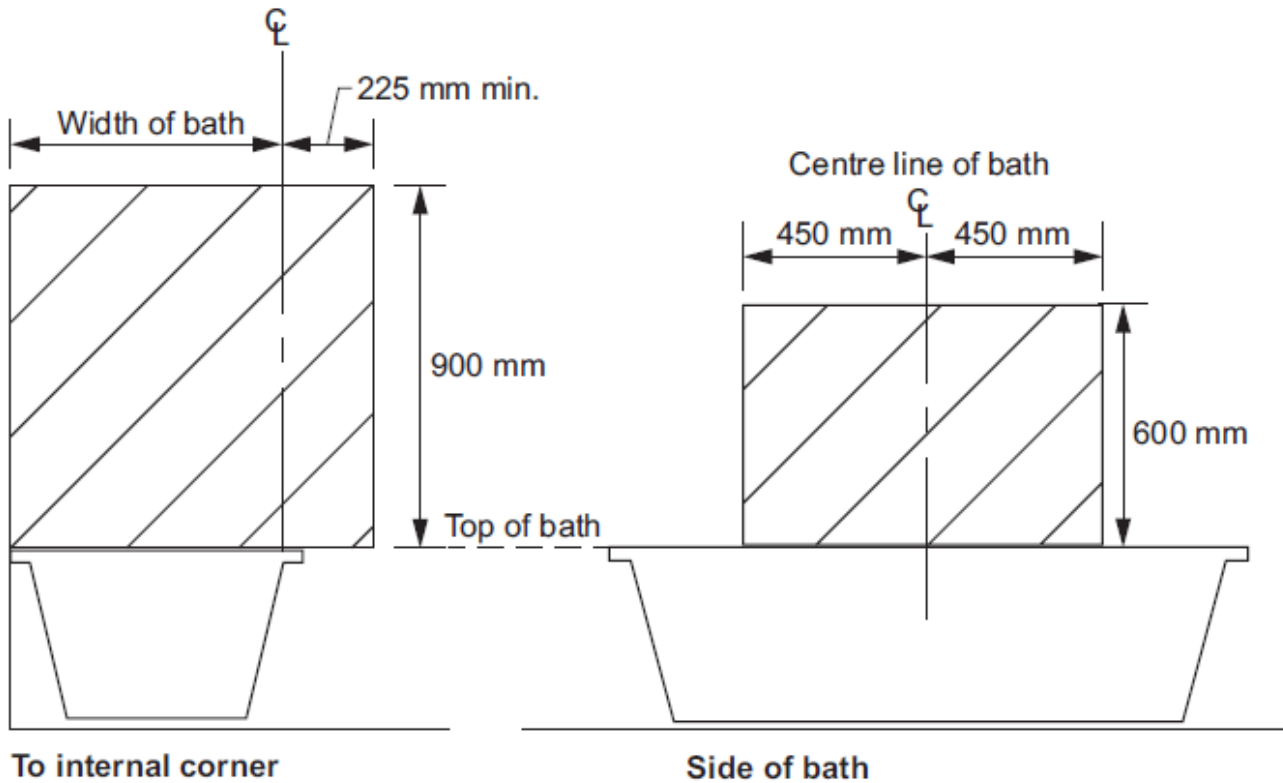

Notes to Figure 6.2b:

- (1) Taps, bath niches, soap holders and the like may be located within the positions designated for wall reinforcing.
- (2) Where the height of the bathtub is not yet known, an assumed height of 500 mm above finished floor level may be used to determine the location of wall reinforcing.

Figure 6.2c Location of noggings for shower walls

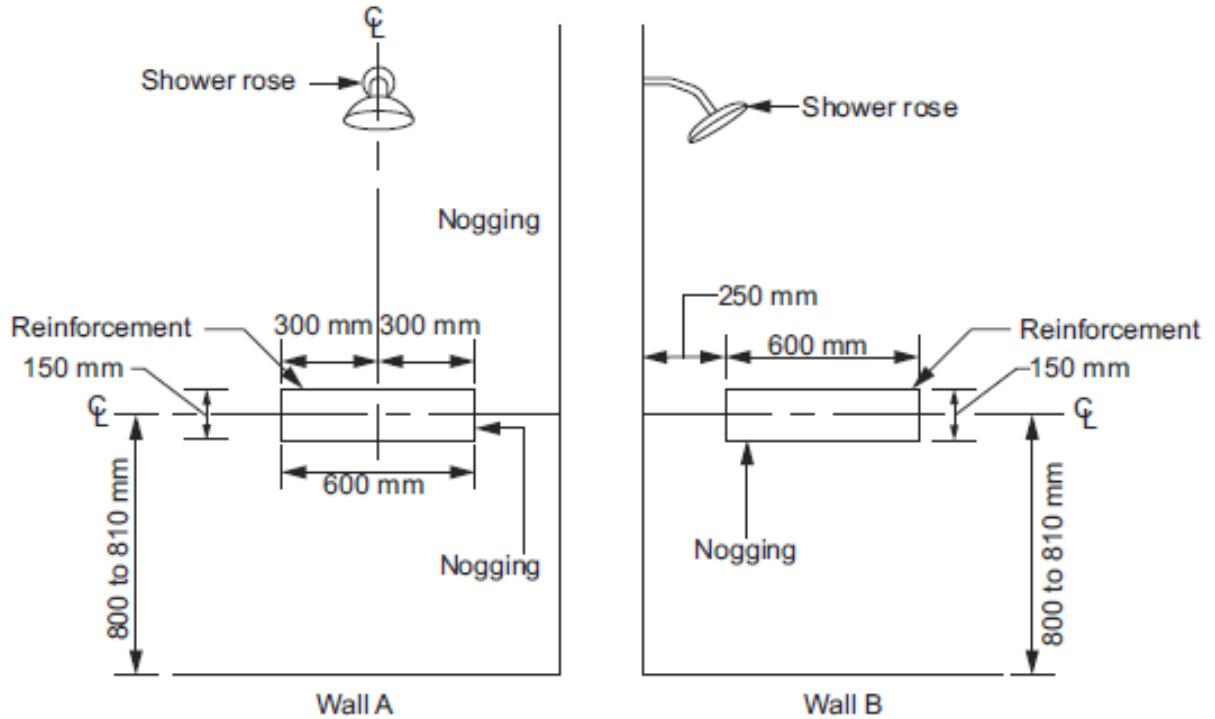

Notes to Figure 6.2c:

Taps, shower niches, soap holders and the like may be located within the positions designated for wall reinforcing.

Figure 6.2d Location of sheeting for shower walls

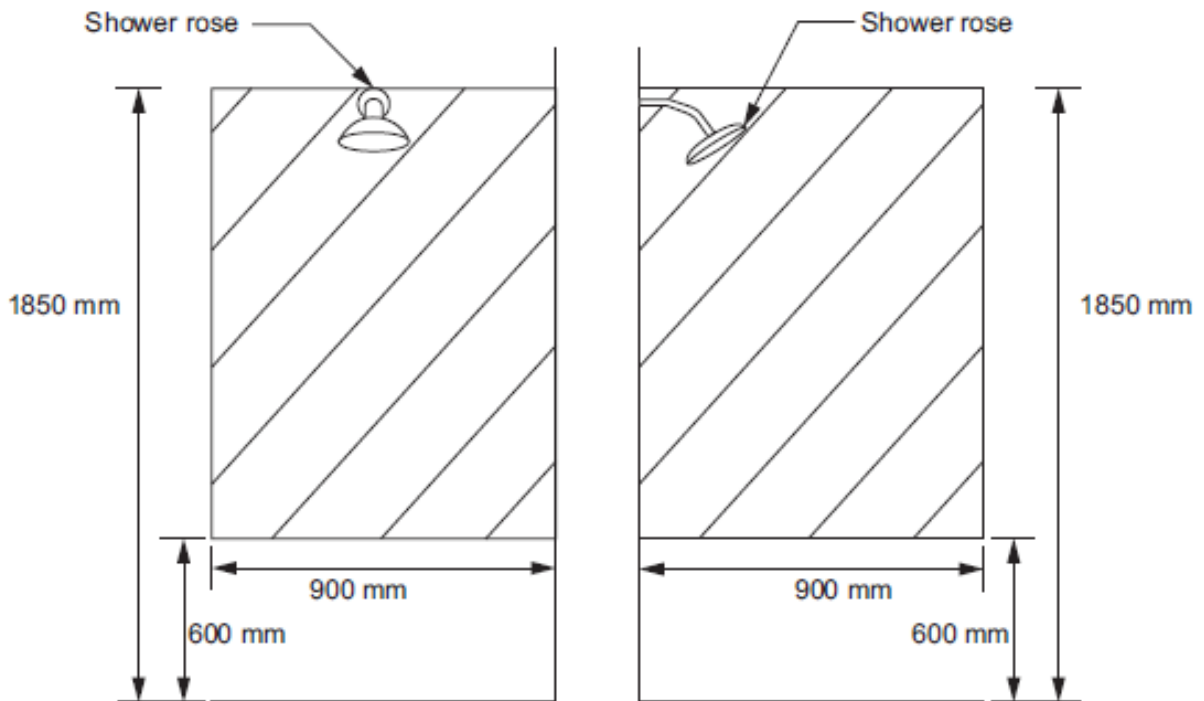

Notes to Figure 6.2d:

Taps, shower niches, soap holders and the like may be located within the positions designated for wall reinforcing.

Figure 6.2e Minimum extent of sheeting for a wall adjacent to a toilet pan

Minimum extent of structural sheeting clear of any door frame, window frame or wall opening

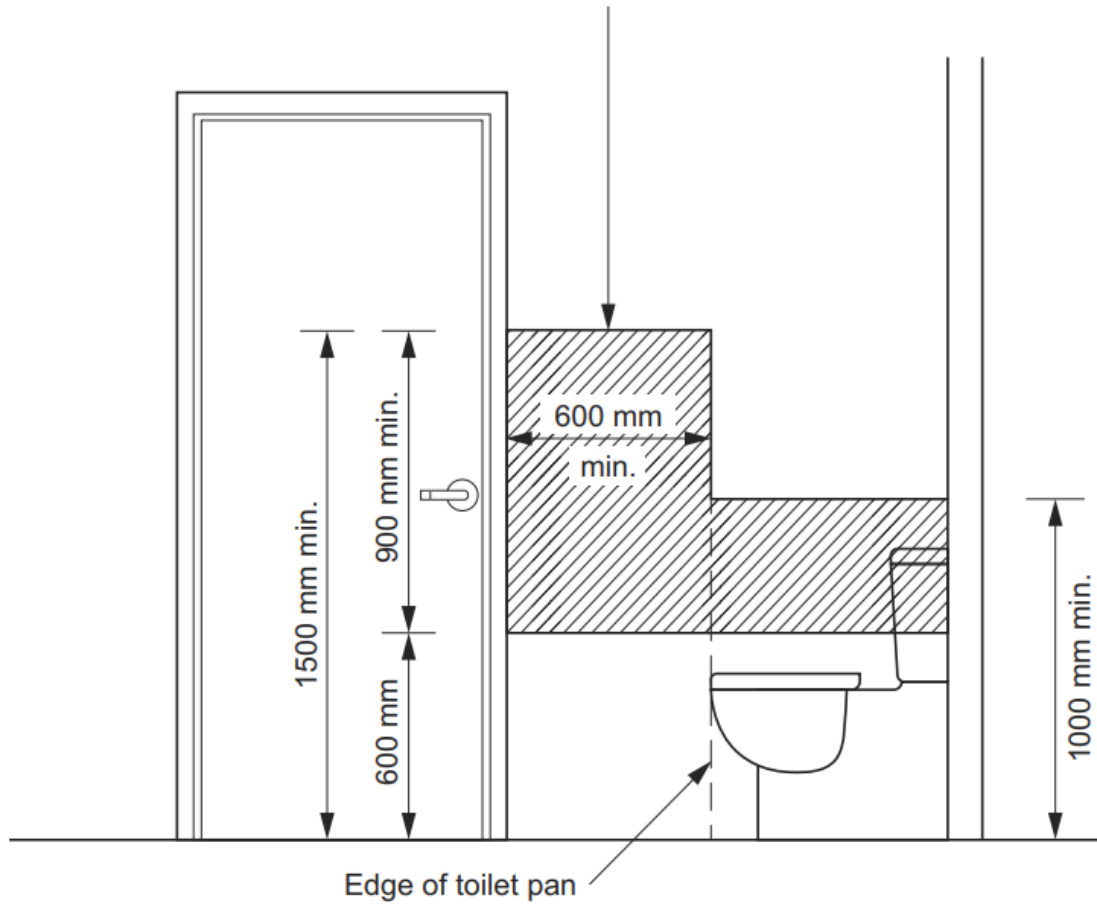

Figure 6.2f Location of noggings for a wall behind a toilet pan

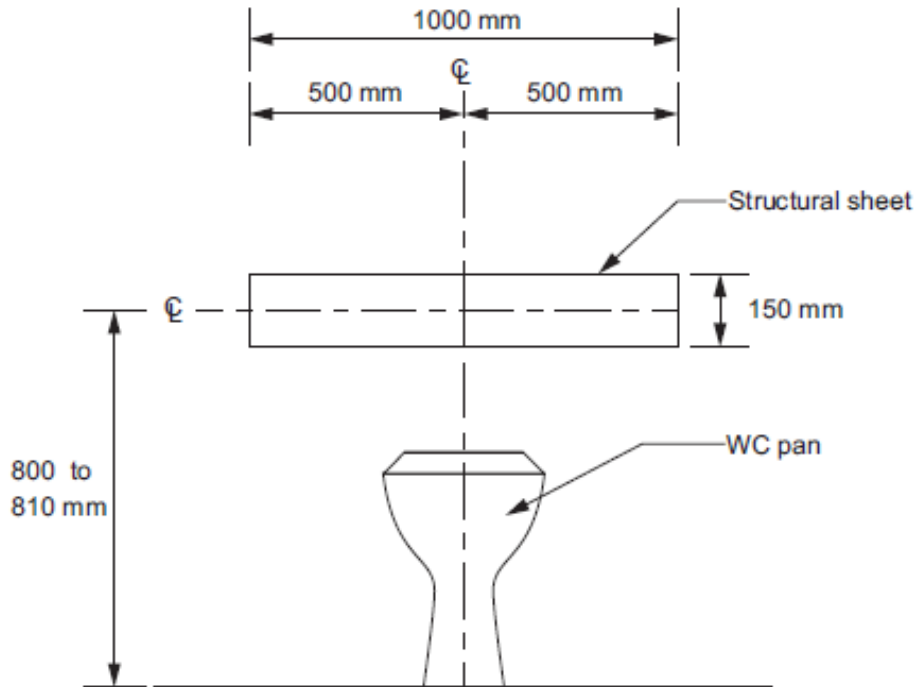
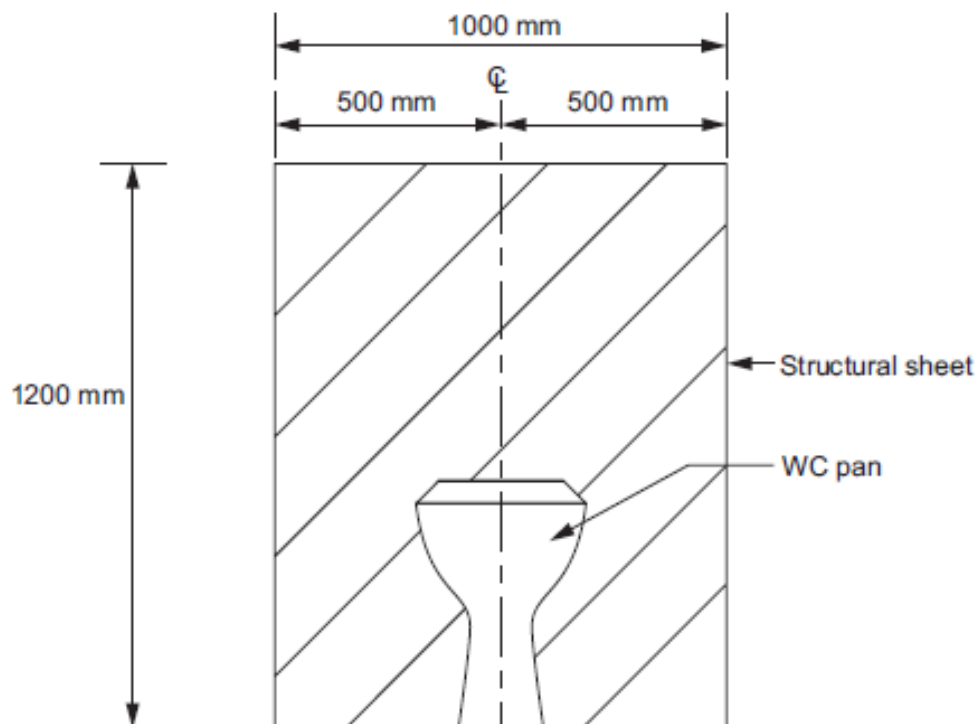

Figure 6.2g Location of sheeting for a wall behind a toilet pan



Comparison to the ABCB Standard for Livable Housing Design

This clause is identical to Clause 6.2 of the ABCB Standard for Livable Housing Design.

7 Internal stairways

7.1 Location

Where an internal stairway is provided within a dwelling, it must be positioned—

- (a) adjoining a wall that is capable of supporting a handrail; or
- (b) if the stairway contains more than one *flight*, with its longest *flight* adjoining a wall that is capable of supporting a handrail.

Information

A handrail must be provided in accordance with the relevant requirements of the NCC.

7.2 Construction

A stairway that is subject to Clause 7.1 must be constructed in accordance with the following:

- (a) Each *flight* must have a minimum clear width of 1000 mm.
- (b) *Winders* must not be used.
- (c) *Spiral stairways* must not be used.
- (d) Positioned adjacent to a wall structurally capable of supporting installation of a chairlift.

Information

The NCC includes other requirements which may also be applicable to a stairway that is subject to Clause 7.2. These include, but are not limited to, the following:

- Dimensions and construction requirements for *risers* and *goings*.
- Balustrades and handrails.
- Location of stairways.
- Maximum number of steps in each *flight*.
- Slip resistance of stair treads.



Comparison to the ABCB Standard for Livable Housing Design

This Part does not appear in the ABCB Standard for Livable Housing Design.

8 Kitchen

8.1 Circulation space

- (1) A kitchen must provide not less than 1200 mm circulation space in front of fixed benches and appliances or spaces for appliances.
- (2) The space required by (1) must be measured from the face of cabinet doors or appliance locations, disregarding any handles, benchtop overhangs and the like.

Comparison to the ABCB Standard for Livable Housing Design

This Part does not appear in the ABCB Standard for Livable Housing Design.

8.2 Floor finishes

Floor finishes must—

- (a) be slip resistant; and
- (b) extend under cabinetry.

Comparison to the ABCB Standard for Livable Housing Design

This Part does not appear in the ABCB Standard for Livable Housing Design.

9 Laundry

9.1 Circulation space

- (1) A laundry space must provide not less than 1200 mm circulation space in front of a washtub and any other fixed benches, appliances or spaces for appliances.
- (2) The space required by (1) must be measured from the face of cabinet doors or appliance locations, disregarding any handles, benchtop overhangs and the like.
- (3) Where space is provided for a washing machine, it must be not less than 600 mm in depth and must not overlap with the space required by (1).

Information

A laundry contained within a closet (also referred to as a 'European laundry') can achieve compliance with this clause if the room or space that the closet opens on to provides the required circulation space.

Comparison to the ABCB Standard for Livable Housing Design

This Part does not appear in the ABCB Standard for Livable Housing Design.

9.2 Floor finishes

Floor finishes must—

- (a) be slip resistant; and
- (b) extend under cabinetry.

Comparison to the ABCB Standard for Livable Housing Design

This Part does not appear in the ABCB Standard for Livable Housing Design.

10 Bedroom space

10.1 Location and circulation space

- (1) There must be a suitable room or space on the ground or entry level of the dwelling that—
 - (a) has a floor space of not less than 10 m²; and
 - (b) provides a clear path of travel not less than 1000 mm wide along at least one side of the space intended for placement of a bed.
- (2) For the purposes of (1)(a), the area of the required floor space must be measured exclusive of—
 - (a) any wall linings, skirting boards or fixed wardrobes; and
 - (b) the swing arc of any door that opens into the room or space.
- (3) Within the space required by (1)(a), the space for placement of a bed must—
 - (a) be rectangular, with dimensions of not less than 1520 mm x 2030 mm; and
 - (b) not overlap with the space required by (1)(b).

Comparison to the ABCB Standard for Livable Housing Design

This Part does not appear in the ABCB Standard for Livable Housing Design.

10.2 Suitability

For the purposes of Clause 10.1(1), a room is considered suitable if it is—

- (a) a habitable room; and
- (b) provided with natural light and ventilation in accordance with the relevant requirements for habitable rooms set out in NCC Volume One or Two, as appropriate.

Comparison to the ABCB Standard for Livable Housing Design

This Part does not appear in the ABCB Standard for Livable Housing Design.

11 Light switches and general power outlets

11.1 Height and location

- (1) Light switches must be positioned—
 - (a) at a height of not less than 900 mm, but not more than 1100 mm, above the finished floor level; and
 - (b) if installed adjacent to a doorway, horizontally aligned with the door handle.
- (2) General power outlets must be positioned not less than 300 mm above the finished floor level.
- (3) The requirements of (1) and (2) need not be complied with where—
 - (a) doing so would result in a risk to the safety of users; or
 - (b) the light switch or general power outlet is located above a fixed benchtop, shelf or the like.
- (4) The requirements of (2) do not apply to general power outlets that are provided for a specific purpose which necessitates their location at a specific height.

Information

Safety requirements applicable to the positioning of lights switches and general power outlets may exist in other regulations, such as electrical safety standards. It is not the intent of this Voluntary Standard to conflict with such regulations.

Comparison to the ABCB Standard for Livable Housing Design

This Part does not appear in the ABCB Standard for Livable Housing Design.

12 Door hardware

12.1 Height above finished floor level

- (1) Door hardware must be located not less than 900 mm and not more than 1100 mm above the finished floor level if the door hardware is a handle or the like which is used to operate—
 - (a) an entrance door that is subject to Part 2; or
 - (b) an internal door that is subject to Part 3.
- (2) The requirements of (1) do not apply where they would be in conflict with the NCC or other regulatory requirements for doors that form part of a swimming pool safety barrier.

Comparison to the ABCB Standard for Livable Housing Design

This Part does not appear in the ABCB Standard for Livable Housing Design.